

16" Deck

Walk Behind Mowers

Attachment

Mfg. No.	Description
881246	ERDP16550, 16" Walk Behind Mower, CE
881247	ERDS16550, 16" Self Propelled Mower, CE

Not for
Reproduction

PRODUCT COMPONENTS	PAGES
Handle Assembly	4
Deck & Engine Group	6
Decals Group	10
Drive Group	12
Torque Specification Chart	Inside Back Cover

Not for
Reproduction

Handle Assembly

NOTE: Unless noted otherwise,
use the standard hardware torque
specification chart.

881246ha

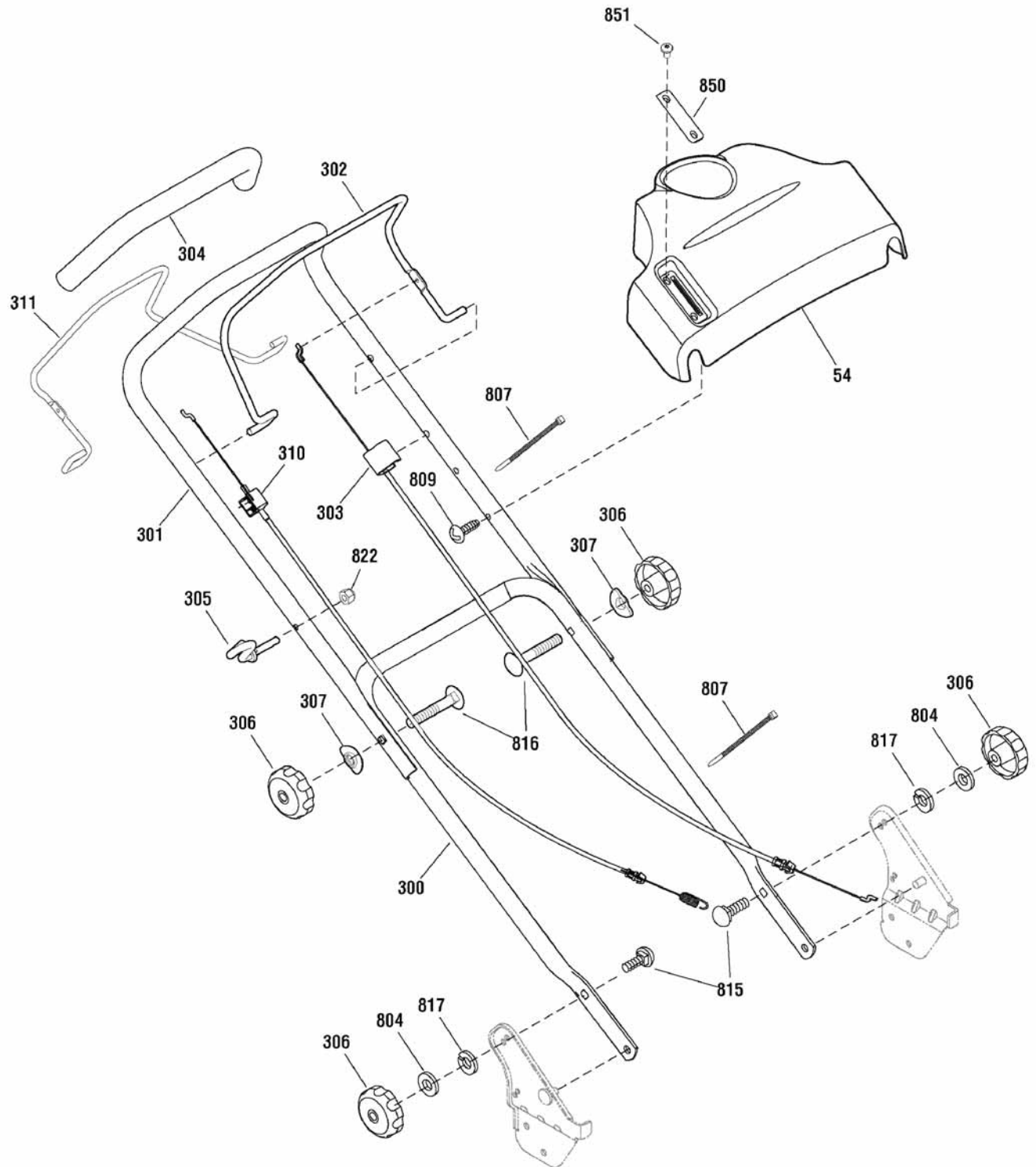

The above parts group applies to the following Mfg. Nos.:

881246 - ERDP16550

881247 - ERDS16550

Handle Assembly

REF NO	PART NO.	QTY.	DESCRIPTION
54	880633	1	CONTROL PANEL
300	880608A	1	HANDLE, Lower
301	880674A	1	HANDLE, Upper
302	880637Z	1	LEVER, Engine Stop
303	880279	1	CABLE, Engine Stop
304	880730	1	TUBING, Foam
305	724994	1	GUIDE, Rope
306	721800	1	KNOB, Adjuster
307	880615	1	WASHER, Formed
310	880475	1	CABLE, Drive (Self Propelled Models Only)
311	881060Z	1	LEVER, Drive (Self Propelled Models Only)
804	880607	1	WASHER, 5/8
807	880029	1	CABLE TIE
809	722856	1	SCREW, Self Tap, #10-16 x 1/2
815	880576	1	BOLT, Carriage, 5/16-18 x 1-1/8
816	720055	1	BOLT, Carriage, 5/16-18 x 2
817	22129GP	1	WASHER, Lock
822	722393	1	NUT, Hex, 1/4-20
850	881236	1	COVER, Throttle
851	722851	2	SCREW, Hex Head, Self Tap, 1/4-14 x 3/8

Not for
Reproduction

Footnotes

The above parts group applies to the following Mfg. Nos.:

881246 - ERDP16550

881247 - ERDS16550

Deck & Engine Group

REF NO	PART NO.	QTY.	DESCRIPTION
1	10T802-0161-B1	1	* ENGINE, B&S 550 Series EU (Engine Model: 10T802-0161-B1)
2	881121C	1	MOWER HOUSING
3	880951A	1	BRACKET ASSEMBLY, Left Handle
4	880950A	1	BRACKET ASSEMBLY, Right Handle
6	881076	1	BLADE, 16"
7	880009	1	BLADE ADAPTER ASSEMBLY (Push Models Only)
7	880567	1	BLADE ADAPTER ASSEMBLY (Self Propelled Models Only)
8	880661	1	DOOR, Rear
9	880213	1	ROD, Rear Door
10	880942	1	SPRING, Torsion Rear Door, Right
11	880944Z	1	FRAME ASSEMBLY
12	880947	1	BAG ASSEMBLY
13	880914	1	MULCH PLUG
14	880943	1	SPRING, Torsion Rear Door, Left
52	880649	1	HOUSING COVER, Front
104	880787	2	SLEEVE ASSEMBLY, Rear Axle
200	880709	2	WHEEL, Rear (Push Models Only)
200	880195	2	WHEEL, Rear (Self Propelled Models Only)
201	880657	2	HUBCAP, Rear
202	880718	2	WHEEL, Front, Complete
203	880656	2	HUBCAP, Front
204	--	4	WHEEL BEARING (Not Available)
205	--	2	SPACER (Not Available)
206	880459	1	CROSSBAR ASSEMBLY, Front
208	880050	2	BUSHING, Front Crossbar
209	881163	2	SPRING, Clip Crossbar
210	880790C	1	LINK, Single Lever
211	880052	1	SPRING, Extension
213	880873	1	REAR CROSSBAR
214	880642	1	SPRING, Adjuster
215	880540	1	LEVER, Height Adjustment
216	880325	1	KNOB, Adjuster
217	880960	1	BRACKET, Height Adjuster
300	880794	1	BAFFLE, Front
301	880793	1	BAFFLE, Rear
302	880664	5	SCREW, 1/4-20 x 1/2
303	880804	5	SCREW, 1/4-15 x 5/8
304	-----	1	SHROUD, With Label
305	-----	1	SCREW, Pan Head
800	720044	3	SCREW, Hex Head, 3/8-16 x 1
801	700011	1	BOLT, Blade, 3/8-24 x 2
802	721890	1	WASHER, Belleville
804	880607	2	WASHER, 5/8
805	880020	2	NUT, Nylock, M8 x 1-1/4

Footnotes

** Not a servicable part, order complete assembly

NOTE: * Purchase engine parts from engine manufacturer dealer.

The above parts group applies to the following Mfg. Nos.:

881246 - ERDP16550

881247 - ERDS16550

Deck & Engine Group

881246dk

NOTE: Unless noted otherwise,
use the standard hardware torque
specification chart.

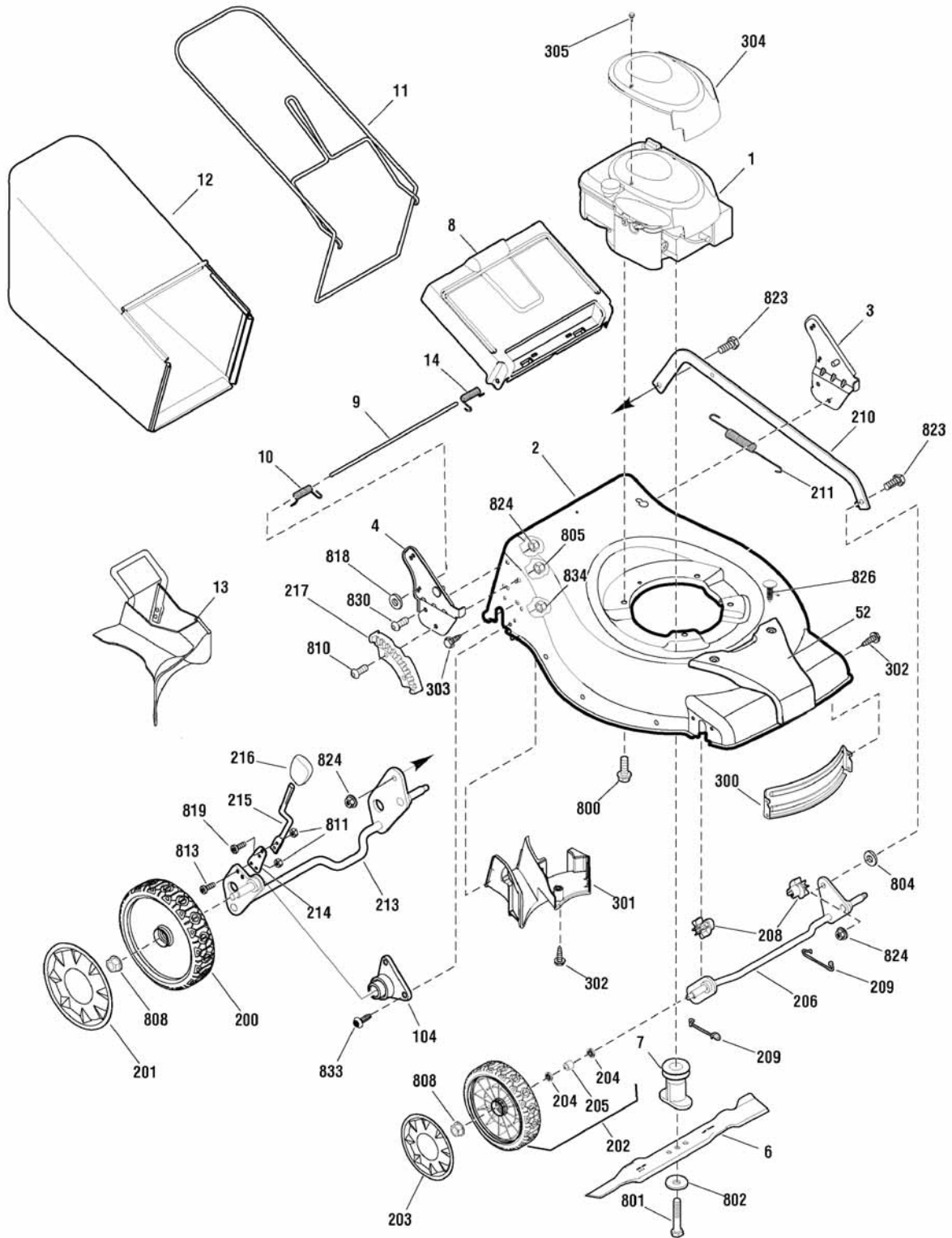

The above parts group applies to the following Mfg. Nos.:

881246 - ERDP16550

881247 - ERDS16550

Deck & Engine Group

REF NO	PART NO.	QTY.	DESCRIPTION
808	720142	4	NUT, Flange, 3/8-16
810	880323	2	BOLT, Hex Key Head
811	880428	4	NUT, Nylock
813	880339	2	SCREW, Torx Head, M5 x .8 x 14mm
818	7091020	2	PUSHNUT, 1/4
819	880577	2	SCREW, Torx Head, M5 x .8 x 12.5mm
823	880651	2	BOLT, Shoulder, 5/16-18 x 1
824	720145	6	NUT, Flange, 5/16-18
826	880456	2	SCREW, 1/4-20 x 7/8
830	727291	4	SCREW , 5/16-18 x 3/4
833	880845	4	SCREW, Torx, 1/4-20 x 5/8
834	880859	6	NUT, Flange Lock, 1/4-20

Not for
Reproduction

Footnotes

** Not a servicable part, order complete assembly

NOTE: * Purchase engine parts from engine manufacturer dealer.

The above parts group applies to the following Mfg. Nos.:

881246 - ERDP16550

881247 - ERDS16550

Decals Group

NOTE: Unless noted otherwise,
use the standard hardware torque
specification chart.

\\log Data\SMP\Images\groups\8800000\881246dc1

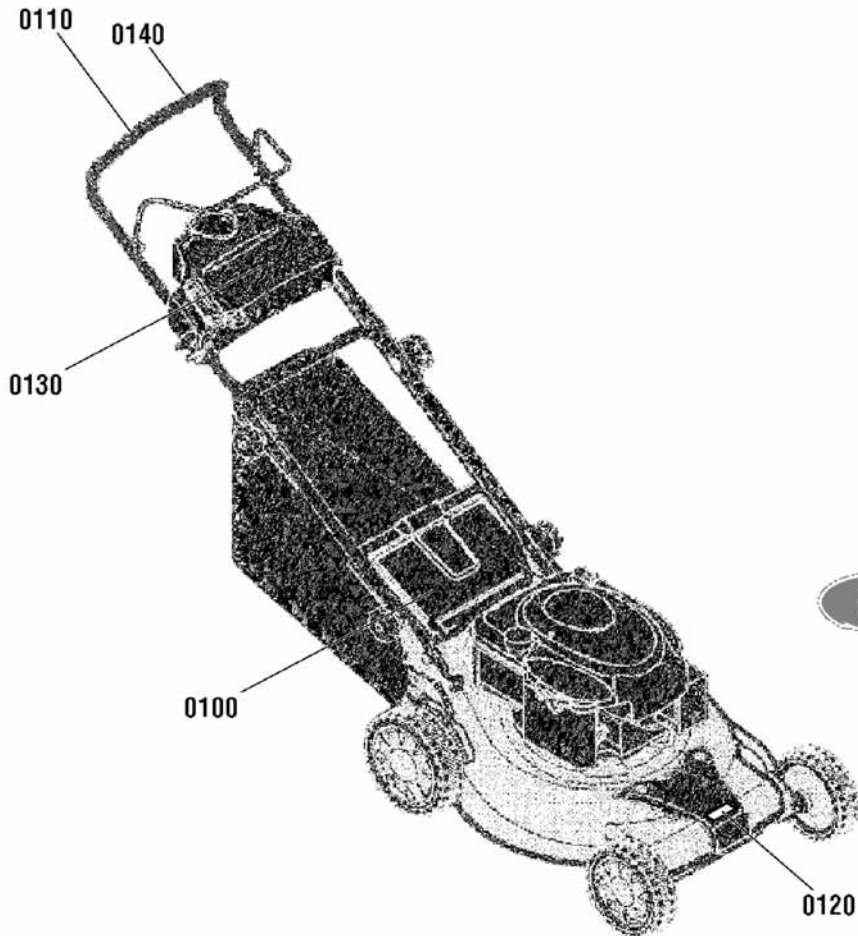

0110



0140



0100



0130

The above parts group applies to the following Mfg. Nos.:

881246 - ERDP16550

881247 - ERDS16550

Decals Group

REF NO	PART NO.	QTY.	DESCRIPTION
0100	880360	1	DECAL, Warning Symbols
0110	880545	1	DECAL, Engine Control Lever
0120	881408	1	DECAL, Logo, Deck
0130	1722551	1	DECAL, Logo, Cover
0140	880544	1	DECAL, Drive Control Lever (Self Propelled Model Only)

Not for
Reproduction

Footnotes

The above parts group applies to the following Mfg. Nos.:

881246 - ERDP16550

881247 - ERDS16550

Drive Group

REF NO	PART NO.	QTY.	DESCRIPTION
100	880379	1	TRANSMISSION
101	880282	1	BELT GUIDE, Transmission
102	880424	1	V-BELT
104	880787	1	SLEEVE ASSEMBLY, Rear Axle
105	880226	1	GEAR, Pinion
106	880225	1	GEAR, Drive
107	880640	1	DUST COVER, LH
108	880796	1	BELT COVER ASSEMBLY
302	880664	2	SCREW, Pan Head Torx, 1/4-20 x 1/2
803	880324	1	WASHER, Thrust
812	880760	3	SCREW, #10 x 1
814	722881	1	SCREW, 1/4-15 x 3/4
821	880269	1	RING, External Retaining
833	880845	4	SCREW, Torx, 1/4-20 x 5/8
834	880859	4	NUT, Flange Lock, 1/4-20
840	880230	1	DUST COVER, RH

Not for
Reproduction

Footnotes

The above parts group applies to the following Mfg. Nos.:

881247 - ERDS16550

Not for
Reproduction

Hardware Identification & Torque Specifications

Torque Specification Chart								
FOR STANDARD METRIC MACHINE HARDWARE (Tolerance ± 20%)								
Property Class	5.6		8.8		10.9		12.9	
	Class 5.6		Class 8.8		Class 10.9		Class 12.9	
Size Of Hardware	in/lbs	Nm.	in/lbs	Nm.	in/lbs	Nm.	in/lbs	Nm.
	ft/lbs		ft/lbs		ft/lbs		ft/lbs	
M3	5.88	.56	13.44	1.28	19.2	1.80	22.92	2.15
M4	13.44	1.28	30.72	2.90	43.44	4.10	52.56	4.95
M5	26.4	2.50	60.96	5.75	5.97	8.10	7.15	9.7
M6	44.64	4.3	7.3	9.9	10.3	14	12.1	16.5
M7	5.2	7.1	12.1	16.5	16.9	23	19.9	27
M8	7.7	10.5	17.7	24	25	34	29	40
M10	15	21	35	48	50	67	59	81
M12	26	36	61	83	86.2	117	103	140
M14	42	58	101	132	136	185	162	220
M16	64	88	147	200	210	285	250	340
M18	89	121	202	275	287	390	346	470
M20	126	171	290	390	405	550	486	660
M22	169	230	390	530	559	745	656	890
M24	217	295	497	375	708	960	840	1140
M27	320	435	733	995	1032	1400	1239	1680
M30	435	590	995	1350	1401	1900	1681	2280
M33	590	800	1349	1830	1902	2580	2278	3090
M36	759	1030	1740	2360	2441	3310	2935	3980
M39	988	1340	2249	3050	3163	4290	3798	5150

Torque Specification Chart						
FOR STANDARD MACHINE HARDWARE (Tolerance ± 20%)						
Hardware Grade	No Marks		SAE Grade 5		SAE Grade 8	
	SAE Grade 2		SAE Grade 5		SAE Grade 8	
Size Of Hardware	in/lbs	Nm.	in/lbs	Nm.	in/lbs	Nm.
	ft/lbs		ft/lbs		ft/lbs	
8-32	19	2.1	30	3.4	41	4.6
8-36	20	2.3	31	3.5	43	4.9
10-24	27	3.1	43	4.9	60	6.8
10-32	31	3.5	49	5.5	68	7.7
1/4-20	66	7.6	8	10.9	12	16.3
1/4-28	76	8.6	10	13.6	14	19.0
5/16-18	11	15.0	17	23.1	25	34.0
5/16-24	12	16.3	19	25.8	29	34.0
3/8-16	20	27.2	30	40.8	45	61.2
3/8-24	23	31.3	35	47.6	50	68.0
7/16-14	30	40.8	50	68.0	70	95.2
7/16-20	35	47.6	55	74.8	80	108.8
1/2-13	50	68.0	75	102.0	110	149.6
1/2-20	55	74.8	90	122.4	120	163.2
9/16-12	65	88.4	110	149.6	150	204.0
9/16-18	75	102.0	120	163.2	170	231.2
5/8-11	90	122.4	150	204.0	220	299.2
5/8-18	100	136	180	244.8	240	326.4
3/4-10	160	217.6	260	353.6	386	525.0
3/4-16	180	244.8	300	408.0	420	571.2
7/8-9	140	190.4	400	544.0	600	816.0
7/8-14	155	210.8	440	598.4	660	897.6
1-8	220	299.2	580	788.8	900	1,244.0
1-12	240	326.4	640	870.4	1,000	1,360.0

The guides and ruler furnished below are designed to help you select the appropriate hardware.



Nut, M8

Thread Diameter (mm)
Inside Diameter (in)
Threads per inch

Nut, 1/2-16

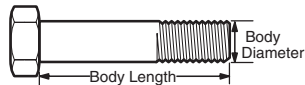

Screw, M8- 1.25 x 25

Thread Diameter (mm)
Body Diameter
Distance between threads (mm)
Threads per inch
Body Length (mm)
Body Length (in)

Screw, 1/2- 16 x 2



Standard Hardware Sizing

When a washer or nut is identified as **1/2"** (M8), this is the *Nominal size*, meaning the *inside diameter* is 1/2 inch (8mm metric thread diameter); if a second number is present it represents the *threads per inch* (distance between threads).

When bolt or capscrew is identified as **1/2 - 16 x 2"** (M8 - 1.25 x 50), this means the *Nominal size*, or body diameter is 1/2 inch (8mm metric thread diameter), the second number, 16, represents the *threads per inch*, (1.25 thread diameter). The final number is the body length of the bolt or screw, 2 inches (50mm).

NOTES

- These torque values are to be used for all hardware excluding: locknuts, self-tapping screws, thread forming screws, sheet metal screws and socket head setscrews.
- Recommended seating torque values for locknuts:
 - for prevailing torque locknuts - use 65% of grade 5 torques.
 - for flange whizlock nuts and screws - use 135% of grade 5 torques.
- Unless otherwise noted on assembly drawings, all torque values must meet this specification.

Common Hardware Types

Hex Head Capscrew

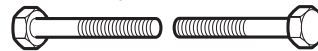

Washer

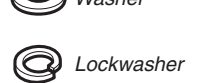

Carriage Bolt

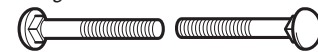

Hex Nut

Wrench & Fastener Size Guide

1/4" Bolt or Nut Wrench—7/16"	5/16" Bolt or Nut Wrench—1/2"	3/8" Bolt or Nut Wrench—9/16"	7/16" Bolt or Nut Wrench (Bolt)—5/8" Wrench (Nut)—11/16"	1/2" Bolt or Nut Wrench—3/4"
M6 Bolt or Nut Wrench—10mm	M8 Bolt or Nut Wrench—13mm	M10 Bolt or Nut Wrench—17mm	M12 Bolt or Nut Wrench—19mm	M14 Bolt or Nut Wrench—22mm

Not for
Reproduction

**IT IS THE POLICY OF BRIGGS & STRATTON CORP. TO IMPROVE ITS PRODUCTS
WHENEVER IT IS POSSIBLE AND PRACTICAL TO DO SO. WE RESERVE THE RIGHT TO
MAKE CHANGES OR ADD IMPROVEMENTS AT ANY TIME WITHOUT INCURRING ANY
OBLIGATION TO MAKE SUCH CHANGES ON PRODUCTS.**

Briggs & Stratton Yard Power Products Group

3515 N. 124 Street / PO Box 702
Wauwatosa, WI 53222 USA

www.simplicitymfg.com

© Copyright 2010 by Briggs & Stratton Corporation
Milwaukee, WI, USA. All rights reserved